



# Moderniek Bagtipper

## Mechanical Unloading Module (MUM)



### Concept:

1. (Automatic) transfer ULD's from dolly's on the transportsystem and visa versa with the Container Transfer Module (CTM).
2. Transport ULD's with the Automatic Loadunit Transportsystem (ALT), also manually drivable. (redundancy)
3. Mechanical Unloading Module (MUM):

- **Bagtipper**

Unloads ULD's automatically or with manual control. Bags are sliding out in layers and separated.

- **Bagliner**

Aligns bags short side leading.

- **Upwheeler**

Bags with wheels down are rolled over 180 degrees.

### Bagtipper benefits

- Turn key, plug and play
- Investment relative low
- Proven technology (operation since 2009)
- Performance, high capacity
- Ergonomics, physical conditions
- Reduced ULD area (m<sup>2</sup>/ULD)

#### Moderniek CTM



#### Moderniek ALT



#### Moderniek Bagliner



#### Moderniek Upwheeler



### Bagtipper performance

- Up to 1200 bags/hour
- Unloads all pieces of baggage handled by traditional systems
- (Semi)-automatic unloading AKH/AKE
- Automatic unloading 'open' ULD



# Moderniek Bagtipper

Mechanical Unloading Module (MUM)

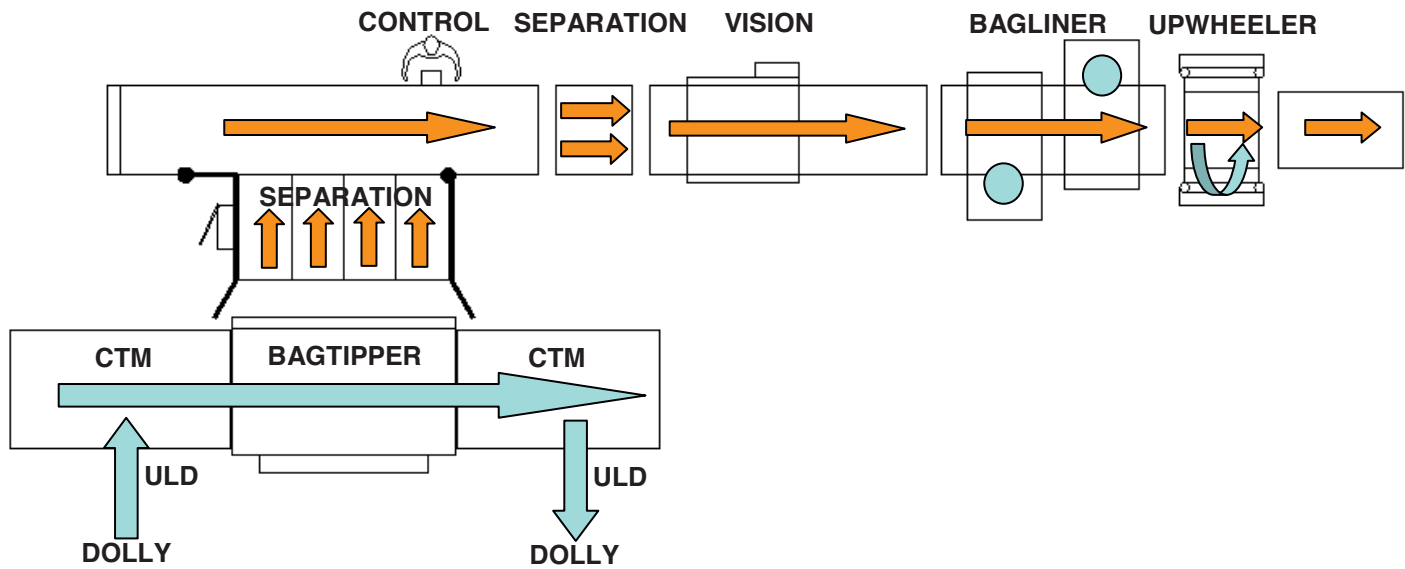

The final layout will depend on the available space, type dolly, type ULD and the desired degree of automation.

More info, Please contact us:

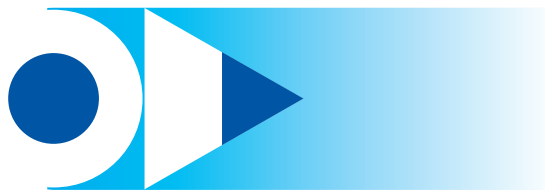

**MODERNIEK B.V.**

info@moderniek.nl